



Intelligent Contingency Ranking of Nigeria’s 330 KV Transmission Network Using Artificial Neural Network

Ihejirika, Chinasa¹, Atuchukwu, John A.², Okonkwo, Innocent I.³, Odigbo, Abigail C.⁴

^{1,4}Nnamdi Azikiwe University, Awka, Nigeria

^{2,3}Chukwuemeka Odumegwu Ojukwu University, Nigeria

Received: 30.05.2026 | Accepted: 26.06.2026 | Published: 01.07.2026

*Corresponding Author: Ihejirika, Chinasa

DOI: [10.5281/zenodo.21075870](https://doi.org/10.5281/zenodo.21075870)

Abstract

Original Research Article

This research examines and prioritizes contingencies within Nigeria’s 330 KV transmission network, concentrating on the South-South and South-East areas. The study utilizes MATLAB/Simulink with actual grid data to evaluate the efficacy of Artificial Neural Network (ANN) in enhancing voltage stability and minimizing power losses during line interruptions. The Voltage Contingency Deviation Index (VCDI) and the Power Contingency Deviation Index (PCDI) were two important measures of how well the system worked. The results reveal that the ANN did a great job of recovering voltage and reducing losses. The results show that using ANN-based control may make Nigeria's power grid more reliable and stable. This is a useful tool for smart contingency management.

Keywords: Contingency Analysis, ANN, Power System Stability, MATLAB, 330 KV Network, Nigeria.

Copyright © 2026 The Author(s). This is an open-access article distributed under the terms of the Creative Commons Attribution-NonCommercial 4.0 International License (CC BY-NC 4.0).

1. INTRODUCTION

Electric power systems form the foundation of modern infrastructure. They enable the generation, transmission, and distribution of electricity from power plants to end users with efficiency and reliability. Any disturbance in this process, such as equipment failure, line outage, or environmental stress, can disrupt power flow and compromise system stability. Contingency analysis is a key aspect of power system studies. It helps determine how vulnerable transmission lines are to faults and ranks them according to their impact on overall network performance. This ranking supports preventive and

corrective actions that strengthen stability, reliability, and security. In practice, contingency analysis provides operators with a clearer understanding of the system’s current state and highlights weak or fault-prone areas that require attention (Mohanty et al., 2024).

Nigeria’s power network provides a strong case for this study. With a population exceeding 200 million as of 2020, the nation’s electricity demand continues to rise while supply remains critically low. Only about 0.123% of the required power is currently available (Obi et al., 2025). The Nigerian power grid faces frequent outages, low generation capacity, and



high transmission losses, making it one of the most unstable power systems in Africa (Airboman et al., 2019). These challenges emphasize the urgent need for systematic tools that can identify and mitigate risks within the transmission network.

Transmission systems play a crucial role in linking generation plants to major load centers, ensuring the bulk transfer of power across long distances. However, as networks become more complex, the risk of unforeseen contingencies increases. Events such as sudden line disconnections, equipment faults, and extreme weather can cause voltage instability, overloads, and cascading failures that may result in widespread blackouts (Hailu et al., 2023). To prevent such disruptions, contingency analysis is now a standard practice in both system planning and operation. It allows engineers to evaluate the impact of faults, assess system response, and ensure that grid integrity is maintained under stressed conditions.

This study focuses on the 330 KV transmission lines in the South-South and South-East regions of Nigeria. These lines form a major part of the national grid, transmitting power from key generating stations such as Afam, Okpai, Ughelli, and Sapele. They face various operational and environmental challenges, including corrosion, pollution, flooding, and vandalism, all of which threaten the reliability of the network (Prakash et al., 2024). Because the Nigerian grid is largely radial, a single line failure can trigger cascading faults and lead to widespread instability (Abdulkareem et al., 2021).

To address these challenges, this research applies MATLAB/SIMULINK and Artificial Neural Networks (ANN) to perform contingency analysis and ranking on the 330 KV transmission network. The analysis identifies critical transmission lines and ranks them according to their vulnerability and impact on system stability. Load flow analysis establishes baseline conditions, while performance index-based methods evaluate contingency severity in accordance with IEEE and Nigerian Grid Code standards.

The study aims to provide a structured approach for improving transmission reliability, guiding investment decisions, and supporting the operational

planning efforts of the Transmission Company of Nigeria (TCN) and the Nigerian Electricity Regulatory Commission (NERC). By identifying weak points and proposing mitigation measures, this research contributes to the broader goal of achieving a stable, secure, and sustainable electricity supply across Nigeria.

2. METHODS

2.1 Research Design

This study applied a simulation-based analytical approach to perform contingency analysis and ranking of Nigeria's 330 KV transmission lines, focusing on the South-Southern and South-Eastern regions. The analysis was carried out using the Power System Analysis Toolbox (PSAT) and Power System Library Environment (PSLE) within MATLAB/Simulink. The aim was to assess the reliability and vulnerability of the regional transmission network under line outage conditions and to evaluate the improvement achievable through the use of Artificial Neural Network (ANN) controllers.

2.2 Data Acquisition

Real-time transmission network data were obtained from the National Control Centre (NCC), Osogbo, operated by the Transmission Company of Nigeria (TCN). The dataset included bus parameters, line impedances, distances, and operational voltage levels for the 330 KV grid system. The study focused on 15 transmission lines connecting 15 buses across the South-South and South-East networks, including major generation and transmission substations such as Afam, Alaoji, Ikot-Ekpene, Benin, Sapele, and Delta. The existing power system network was modeled using the Power System Laboratory Environment (PSLE) and the Power System Analytical Tool (PSAT). The contingency ranking of the Nigerian 330 KV network was determined using two key indices: the Voltage Contingency Deviation Index (VCDI) and the Power Contingency Deviation Index (PCDI). The study utilized data representing the 330 KV transmission network comprising 52

interconnected buses across the national grid.

2.3 Network Modeling

The regional 330 KV transmission network was modeled in both PSAT and PSLE environments. The PSAT model was used for steady-state power flow analysis, while the PSLE (Simulink) model supported the implementation of intelligent control systems and dynamic simulation. The modeling process followed these steps:

1. Initialization: Import of bus and line data (voltage ratings, impedances, line lengths).
2. System Configuration: Creation of generation, transmission, and load subsystems.
3. Simulation Environment Setup: Use of ‘psat’ and ‘powerlib’ commands to initialize PSAT and PSLE environments, respectively.
4. Load Flow Analysis: Baseline power flow and voltage profiles were computed using the Newton–Raphson iterative method to determine the system’s pre-contingency operating state.

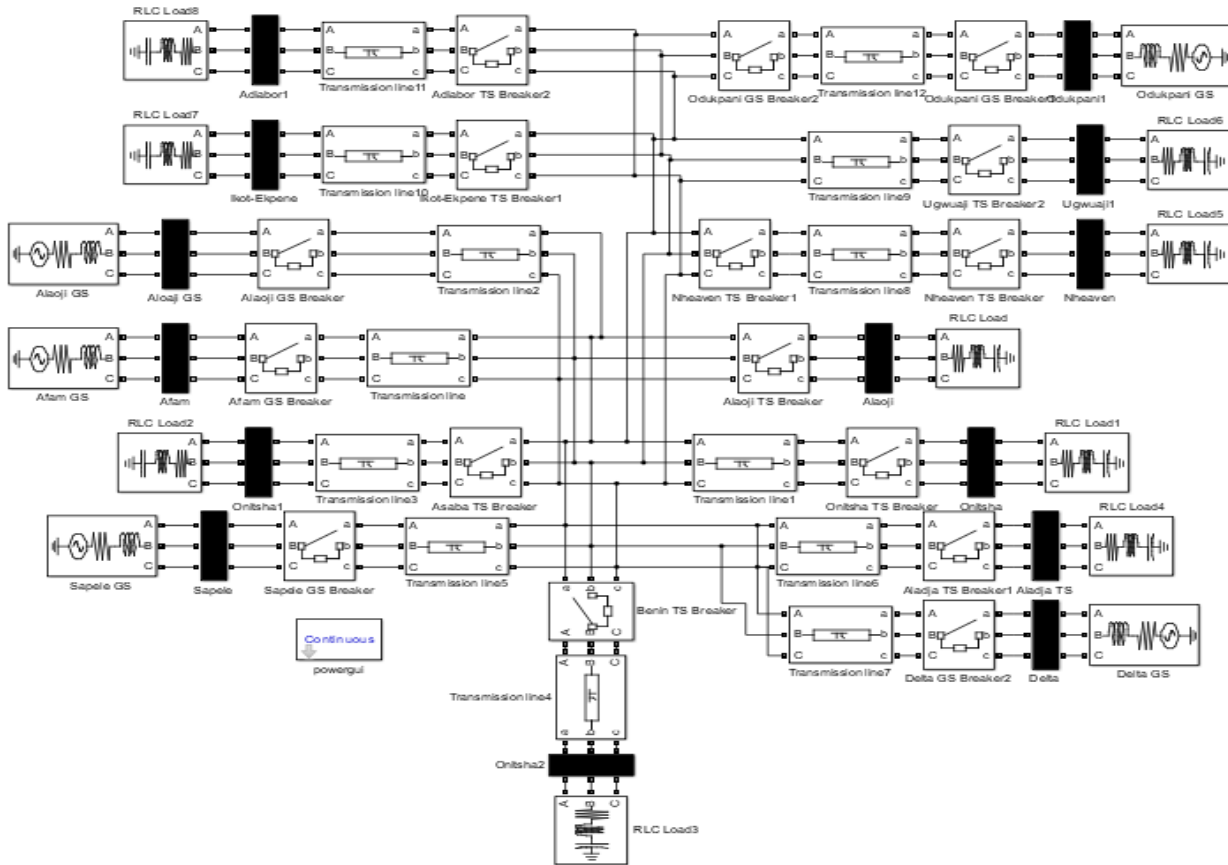

Fig. 1: Model of the power system network with PSLE

2.4 Power Flow Formulation

The power flow analysis was governed by the nonlinear equations:

$$P_i = \sum_{k=1}^n |V_i| |V_k| (G_{ik} \cos \theta_{ik} + B_{ik} \sin \theta_{ik})$$

$$Q_i = \sum_{k=1}^n |V_i| |V_k| (G_{ik} \sin \theta_{ik} - B_{ik} \cos \theta_{ik})$$

where P_i and Q_i are the real and reactive powers at bus i ; V_i and V_k are the bus voltages; and G_{ik} , B_{ik} are the conductance and susceptance between buses i and k . The Newton–Raphson algorithm was employed to iteratively solve the nonlinear equations using the Jacobian matrix until power mismatches were within tolerance limits.

2.5 Artificial Neural Network (ANN)

An ANN-based controller was designed and trained

in MATLAB using Levenberg–Marquardt backpropagation. Input variables included bus voltage, current, and power flow parameters. The ANN had two input neurons, seven hidden neurons with a log-sigmoid activation function, and two output neurons (enhanced voltage and current values). Seventy percent of data were used for training, while 15% each were allocated for testing and validation. The trained ANN was exported to Simulink and embedded within the PSLE model for adaptive voltage regulation.

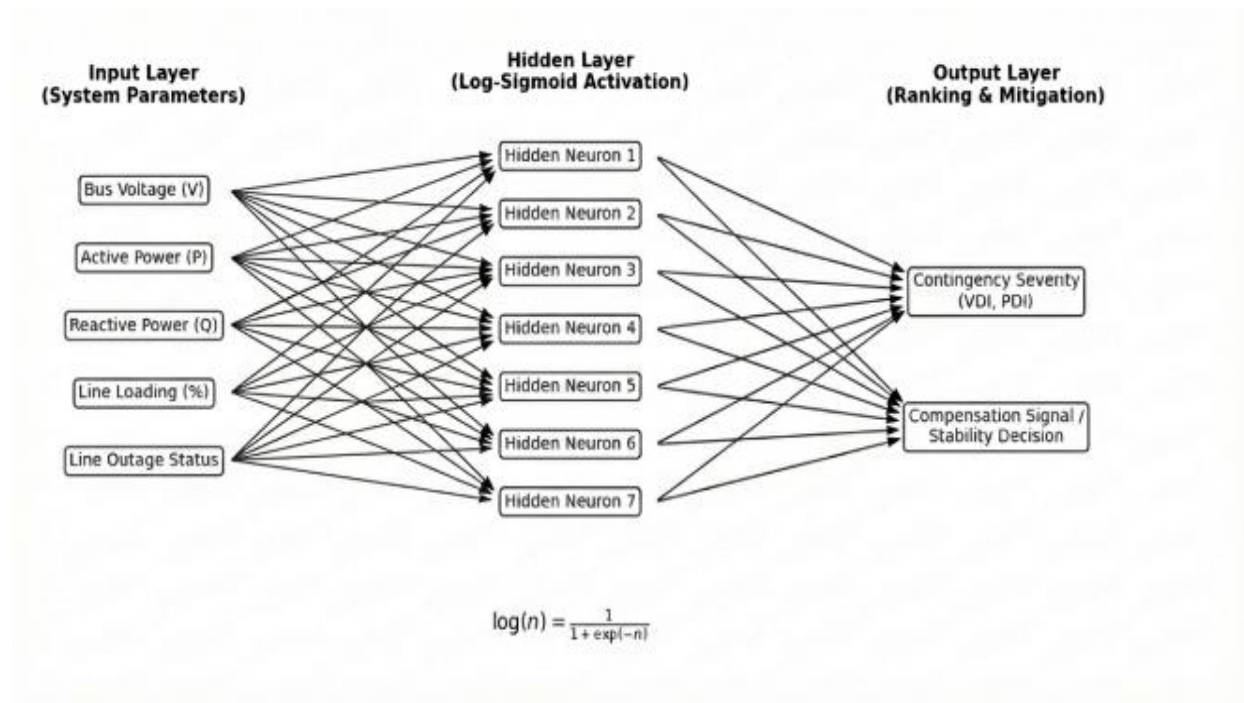

Fig. 2: Structural model of the ANN model

2.6 Contingency Simulation and Ranking

Contingency analysis involved simulating single-line outages sequentially across all 15 transmission lines to determine their individual impact on system stability. For each scenario, post-contingency power flow was computed, and two performance indices were evaluated:

Voltage Contingency Deviation Index (VCDI):

$$VCDI = 330 - \left(\frac{|V_{wo} - V_w|}{n} \times \log \left(\frac{V_{wo}}{V_w} \right) \right)$$

Power Contingency Deviation Index (PCDI):

$$PCDI = 100 - \left(\frac{|P_{wo} - P_w|^{0.8}}{n} \times \log \left(\frac{P_{wo}}{P_w} \right) \right)$$

Where V_{wo} and V_w represents the voltage profile of the power flow analysis without controllers and with controllers, P_{wo} and P_w represents the active power of the system without and with controllers respectively and 'n' represents the number of buses considered.

The lower the contingency indexes, the higher the stability and reliability of the power system network. Contingencies were ranked according to the severity of their VCDI and PCDI values. The line whose outage produced the largest deviation in active power flow and voltage was assigned the highest severity rank.

The impact of the line and generator contingency on the active power flow (in percentage) is

$$\%P_{rank} = \frac{P_T - P_{T(cont)}}{P_T} 100\%$$

Where P_{rank} represents the power ranking, P_T represents the total active power flow for without

DG. The impact of the line and generator contingency on the active power loss(in percentage)

$$\text{is } \%P_{Loss,rank} = \frac{P_{T,Loss} - P_{T,Loss(cont)}}{P_{T,Loss}} 100\%$$

Where $P_{Loss,rank}$ represents the power loss ranking, $P_{T,Loss}$ represents the total active power loss without ANN controllers and $P_{T,Loss(cont)}$ represents the total power loss contingency.

2.7 Performance Evaluation

Comparative simulations were performed under two scenarios:

1. Without any controller (base case),
2. With ANN integration.

Each scenario was analyzed for bus voltage profiles, active and reactive power flows, and corresponding losses. The location with the highest voltage deviation (Adiabor Transmission Substation) was identified as the optimal placement point for the controllers.

3. RESULTS AND DISCUSSION

3.1 Power Flow Analysis of the power system network without ANN

In this study, the results presented were the outcome of the contingency performed which was the removal of the single transmission line representing single line outage connecting Onitsha TS and Benin TS. The power flow analysis data for the Nigerian 330kV power system network for the south east and the south southern region was shown in table 1 and table 2 respectively.

Table 1: Bus voltage data for the system without ANN

Bus No.	Bus location	Voltage flow values (KV)
1	Afam	317.2209

2	Alaoji	318.5869
3	Alaoji	306.9048
4	Ikot-Ekpene	318.7006
5	Odukpani	317854
6	Adiabor	306.4631
7	Onitsha	309.1775
8	Okpai	313.2032
9	New Heaven	319.3626
10	Ugwuaji	319.4733
11	Asaba	307.3642
12	Benin	319.5589
13	Sapele	319.3575
14	Aladja	312.2806
15	Delta	317.0042

The power flow data for the active and reactive power as well as active and reactive power losses were shown in table 2.

Table 2: Power flow analysis of the power system network

Transmission line	Active power (MW)	Active power loss (MW)	Reactive power (MVar)	Reactive power loss (MVar)
1	59.4053	3.3326	86.4149	6.4899
2	66.1223	3.2575	73.6048	5.9684
3	77.9777	3.5987	78.2615	6.1537
4	75.0130	3.7059	73.8773	7.3946
5	79.0278	3.7830	74.8455	6.9092
6	71.7378	2.9692	88.6457	6.4956
7	56.8571	3.6555	86.2017	8.1248
8	76.3791	3.6137	79.0249	7.2899
9	78.4158	2.7764	91.0542	7.1691
10	72.2896	2.7023	73.6545	8.4185
11	74858	3.3472	81.3361	6.2719
12	73.8352	4316	80.2496	7.8745
13	65.4134	3.0787	87.5448	7.8627
14	71.7315	3.4950	88.1088	6.5935
15	60.1085	2.8805	76.5506	7.2306

The power flow analysis of the power system network contained in tables 1 and 2 were further analyzed in the Bar chart shown in figure 3, figure 4, figure 5, figure 6 and figure 7 for voltage profile, real power, reactive power, real power loss and reactive power loss respectively. The least voltage value occurred in Adiabor TS with voltage value of 306.4631kV. hence, the controller was installed in Adiabor TS (for ANN) and on the transmission line connecting Adiabor TS and Odukpani GS

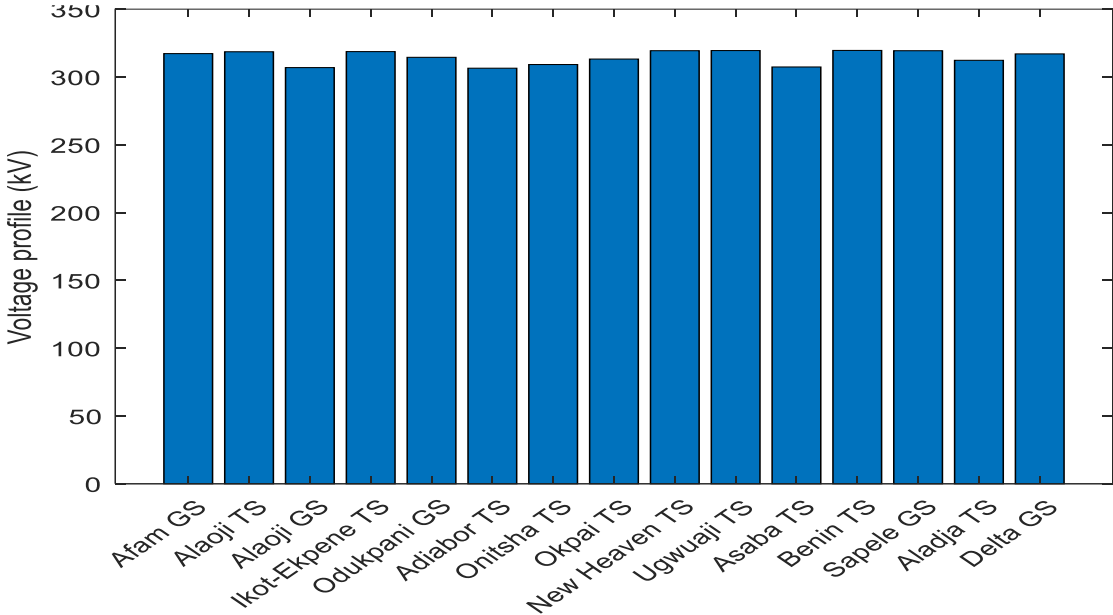

Figure 3; Voltage profile without ANN

The voltage profile in figure 3 can be considered as abnormal because with the introduced contingency, none of the voltage values were up to 320 KV while the expected voltage profile was 330 KV with 1% tolerance.

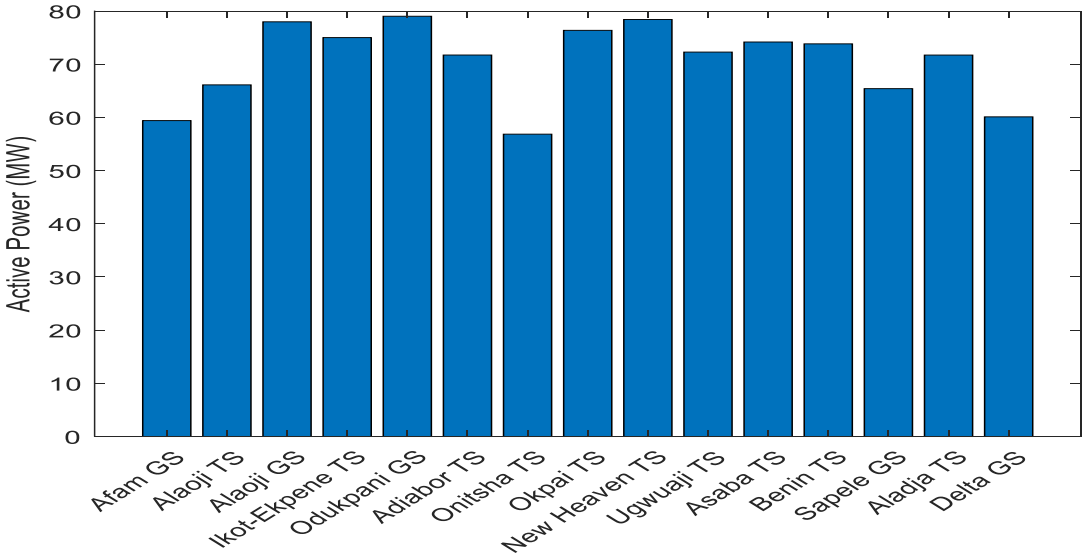

Figure 4; Real power of the power system without ANN

From the bar chart of the active power system network shown in figure 4, it was seen that the real power flow was low with the highest being 79.2 in Odukpani GS. Hence, the introduction of line outage affected the real power flow negatively.

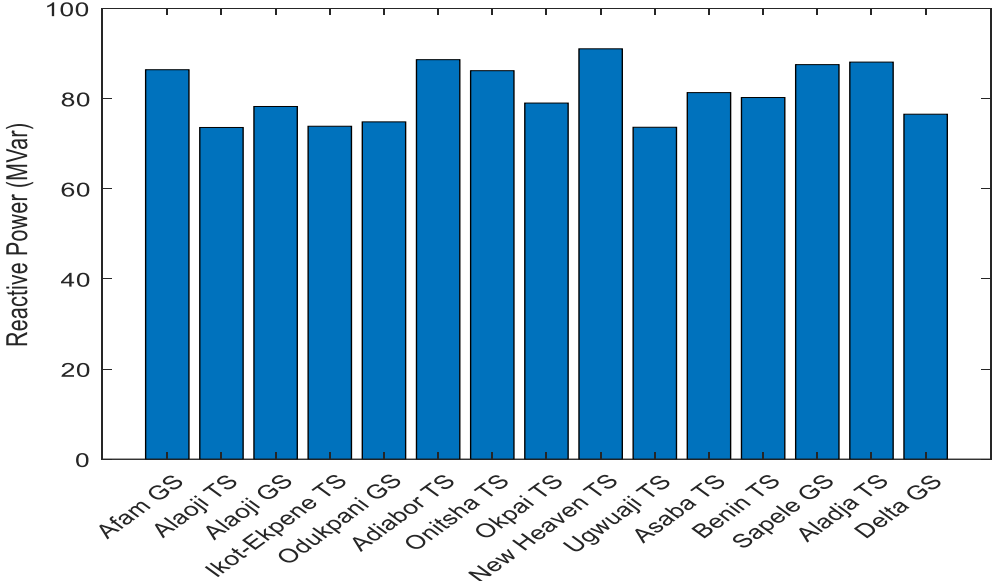

Figure 5; Reactive power of the power system without ANN

The reactive power system shown in figure 5 had a low outcome with none of the values being up to 100MVar. Hence, the line outage contingency after the reactive power network negatively.

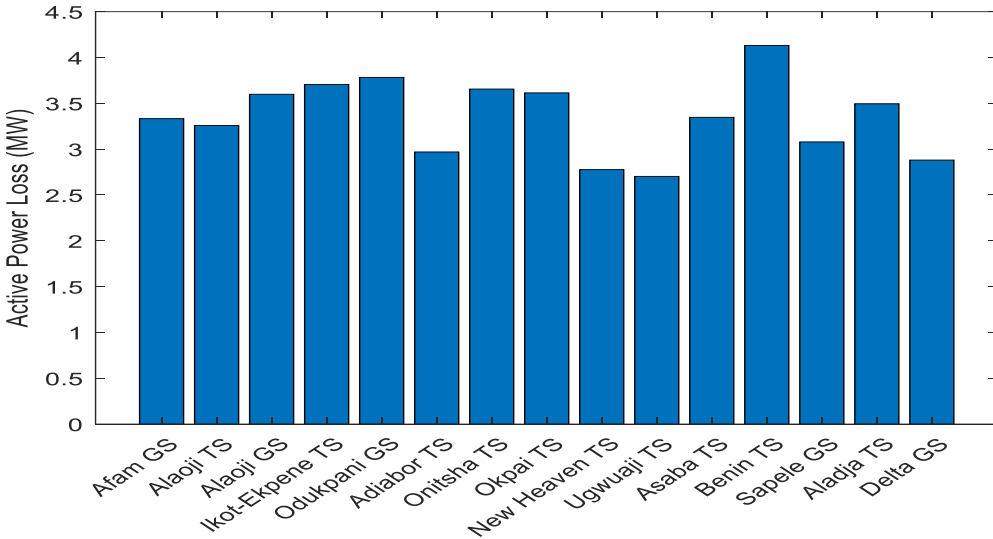

Figure 6; Real power loss of the power system without ANN

The active power loss with the introduction of the outage was high with Benin TS which is the transmission line 12 (Transmission line connecting Bus 12 and 13) having the maximum active power loss of 43 MW which implies that the power losses were more with the introduction of line outages.

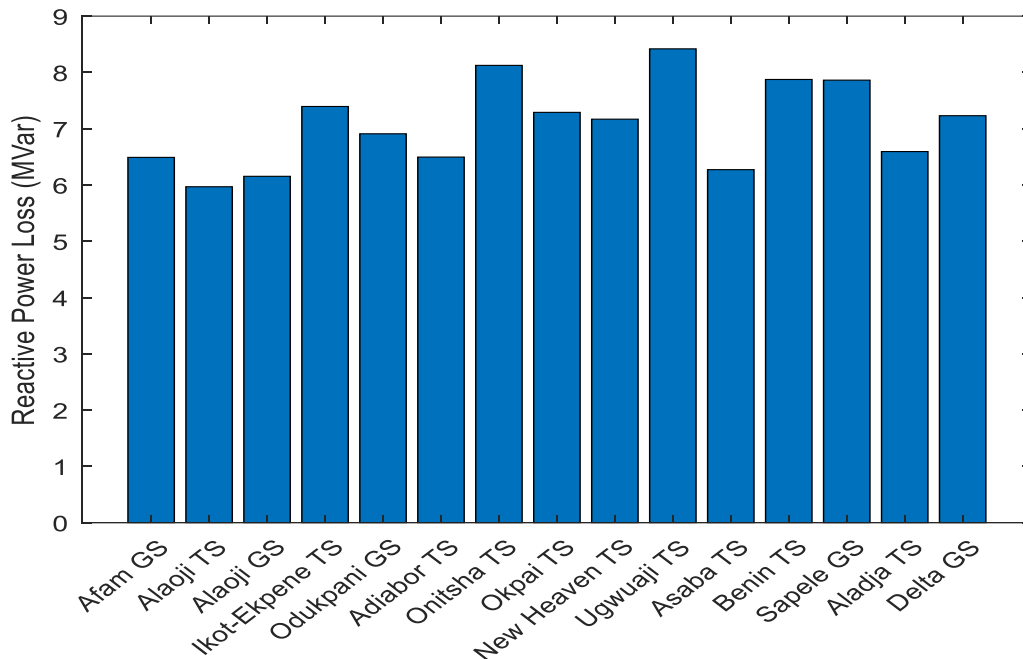

Figure 7; Reactive power loss of the power system without ANN

Ugwuaji TS showed the highest amount of reactive loss of 8.33MVar as shown in figure 7. This shows the more the contingency occurrence, the more the reactive power losses.

3.2 Power Flow Analysis of the power system with ANN

The power flow analysis data for the Nigerian 330kV power system network with ANN for the south east and the south southern region was shown in table 3 and table 4 respectively.

Table 3; Bus voltage data for the system with ANN

Bus location	Voltage flow values (kV)
Afam	326.7375
Alaoji	328.1445
Alaoji	316.1119
Ikot-Ekpene	328.2616
Odukpani	323.9200
Adiababor	315.6570
Onitsha	318.4528
Okpai	322.5993
New Heaven	328.9435
Ugwuaji	329.0575
Asabap	316.5851
Benin	329.1457
Sapele	328.9382
Aladja	321.6490
Delta	326.5143

The power flow data with ANN for the active and reactive power and active and reactive power losses were shown in table 4.

Table 4; Power flow analysis of the power system network with ANN

Transmission line	Active power (MW)	Active power loss (MW)	Reactive power (MVar)	Reactive power loss (MVar)
1	64577	1.4997	99.3771	1.1664
2	71.4121	1.4659	84.6455	1.1401
3	85159	1.6194	90.0007	1.2595
4	81.0140	1.6677	84.9589	1.2971
5	85.3500	1.7024	86.0723	1.3240
6	77.4768	1.3361	101.9426	1.0392
7	61.4057	1.6450	99.1320	1.2794
8	82.4894	1.6262	90.8786	1.2648
9	84.6891	1.2494	104.7123	0.9717
10	78.0728	1.2160	84.7027	0.9458
11	80.1207	1.5062	93.5365	1.1715
12	79.7420	1.8592	92.2870	1.4461
13	70.6465	1.3854	100.6765	1.0775
14	77.4700	1.5728	101.3251	1.2232
15	64.9172	1.2962	88.0332	1.0082

The power flow analysis of the power system network contained in tables 3 and 4 were further analyzed in the Bar charts shown in figure 9, figure 10, figure 11, figure 12 and figure 13 for voltage profile, real power, reactive power, real power loss and reactive power loss respectively.

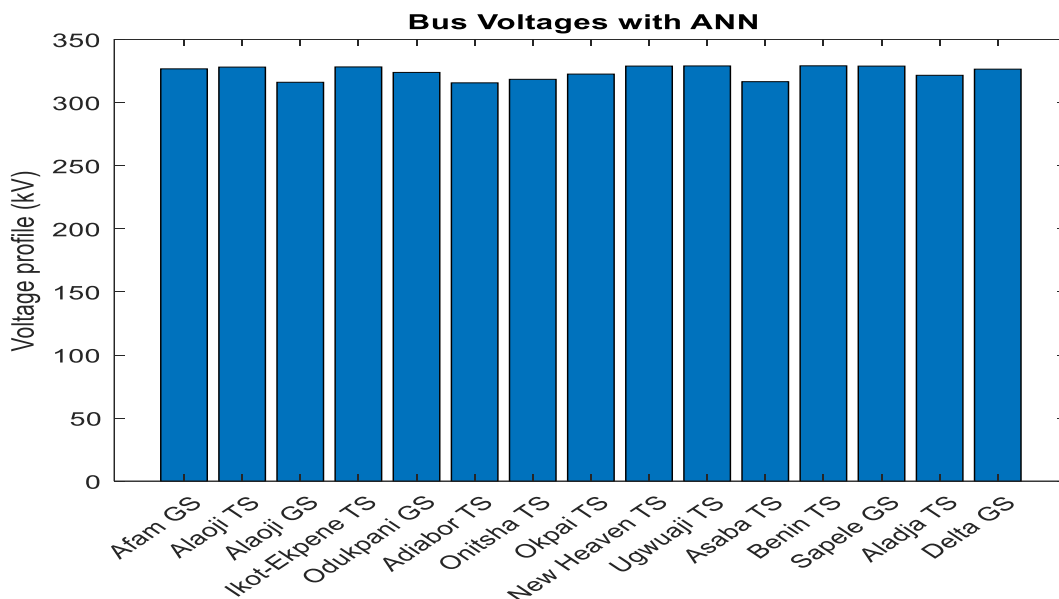

Figure 8; Voltage profile of the power system network with ANN

The introduction of the ANN model as shown in figure 8, had a significant improvement on the voltage profile as the voltage values approached 330kV.

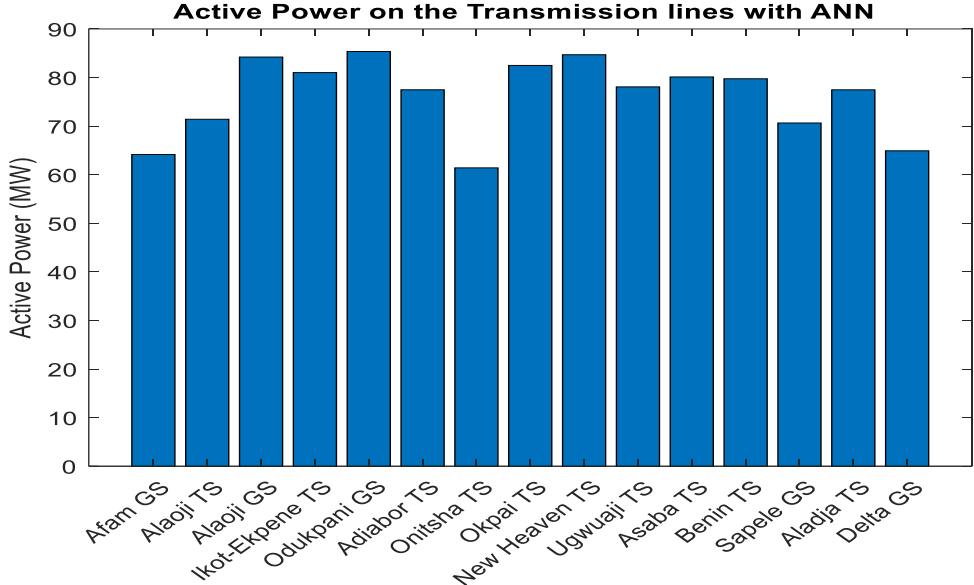

Figure 9; Real power of the power system network with ANN

The introduction of ANN for the active power as shown in figure 9 increased the power flow of the power system network with Odukpani GS having real power value of 86.6MW.

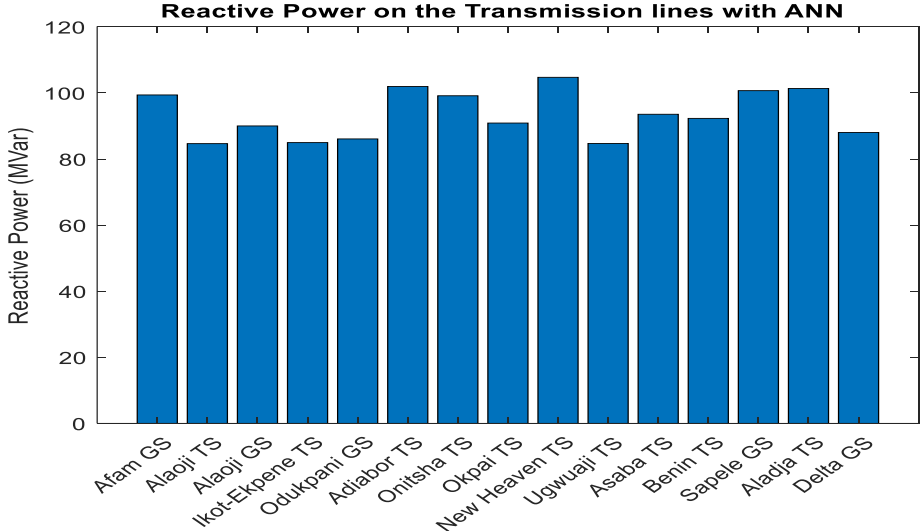

Figure 10; Reactive power of the power system Network with ANN

The introduction of ANN model controller as shown in figure 10 improved the Reactive power of the power system network with New Heaven TS exceeding 100MVar.

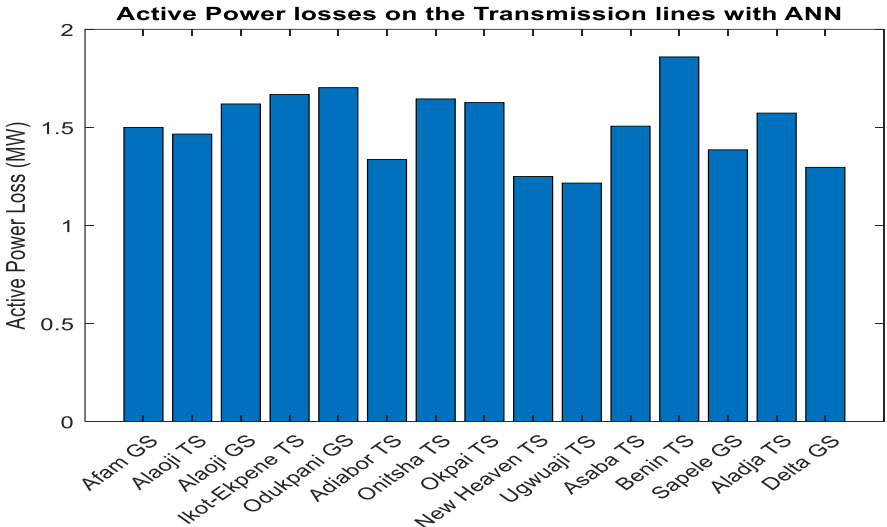

Figure 11; Active power loss of the power system network with ANN

The introduction of ANN model controller reduced the real power losses as shown in figure 11. this implies that ANN can be actively reduce the active losses when utilized in a power system network with line outage.

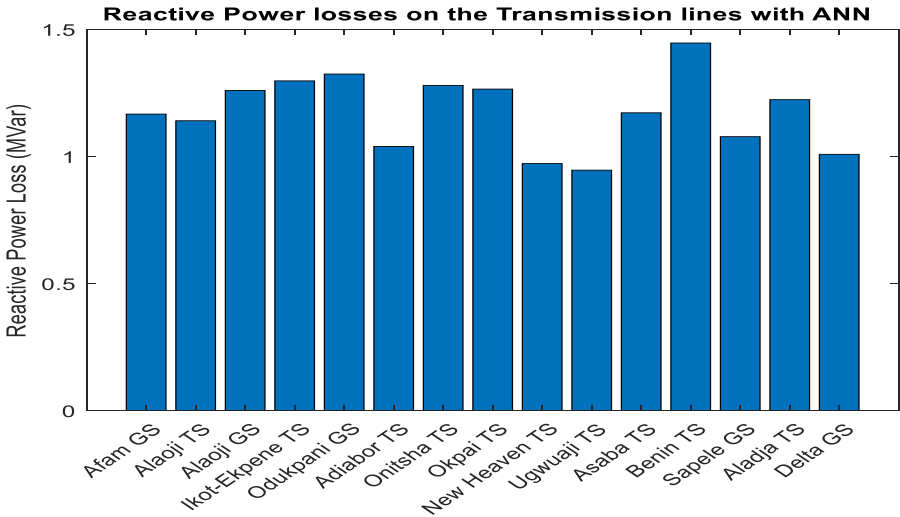

Figure 12; Reactive power loss of the power system network with ANN

The introduction of ANN model controller improved the reactive loss of the power system network as shown in figure 12. The reactive losses were significantly reduced with the utilization of ANN model in the power system network.

Hence, it is suggested that the ANN model controller should be utilized in the power flow improvement with the introduction of contingency issues (line outages).

3.3 Contingency Ranking

The contingency ranking outcome simulated in PSAT is shown in table 5.

Table 5; Contingency ranking with PSAT

Contingency parameters	$\%P_{rank}$	ranking	$\%P_{Loss,rank}$	ranking
Gen 1	3.1297	1	0.0309	1
Line 1	3.1120	2	0.0256	2
Line 2	3.0953	3	0.0247	3
Line 3	3.0891	4	0.0243	4
Line 4	3.0880	5	0.0242	5
Gen 2	2.9594	6	0.0229	6
Line 9	2.9521	7	0.0219	7
Line 6	2.9286	8	0.0211	8
Line 7	2.6451	9	0.2090	9
Line 8	2.6011	10	0.0189	10
Gen 1	2.5760	11	0.0164	11
Line 5	2.1524	12	0.0161	12
Gen 4	2.0798	13	0.0158	13
Gen 5	1.8145	14	0.0144	14
Line 12	1.6236	15	0.0110	15
Line 11	1.4261	16	0.0090	16
Gen 3	0.9815	17	0.0083	17
Line 10	0.6062	18	0.0073	18
Line 13	0.5574	19	0.0061	19
Line 14	0.5112	20	0.0053	20
Line 15	0.4158	21	0.0039	21

Table 6; Contingency ranking with PLSE

Contingency parameters	$\%P_{rank}$	ranking	$\%P_{Loss,rank}$	ranking
Gen 1	3.0665	1	0.0309	1
Line 1	3.0161	2	0.0299	2
Line 2	2.7527	3	0.0287	3
Line 3	2.6730	4	0.0271	4
Line 4	2.4690	5	0.0258	5
Gen 2	2.4237	6	0.0262	6
Line 9	2.3086	7	0.0226	7
Line 6	2.2737	8	0.0199	8
Line 7	2.2238	9	0.0189	9
Line 8	2.1516	10	0.0178	10
Gen 1	1.4789	11	0.0177	11
Line 5	1.3345	12	0.0530	12
Gen 4	1.3014	13	0.0114	13
Gen 5	1.1013	14	0.0113	14
Line 12	0.9766	15	0.0084	15
Line 11	0.6484	16	0.0083	16
Gen 3	0.4185	17	0.0082	17
Line 10	0.2603	18	0.0077	18
Line 13	0.2278	19	0.0064	19

Line 14	0.2239	20	0.0044	20
Line 15	0.2158	21	0.0042	21

Table 5 and 6 showed the contingency ranking when simulated with PSAT and PLSE respectively. It was observed that even at different power flow parameter values, the two applications presented the same ranking positions. Both applications had gen 1 as the contingency that can negatively impact the power system as power flow percentage of 3.1297% and loss percentage of 0.0309% when simulated with PSAT and 3.0665% and 0.0309%.

4. CONCLUSION

Effective planning of a power system network is essential to prevent faults that can reduce system security, reliability and stability. This study focused on the Nigerian 330 KV transmission network, particularly the South-East and South-South regions. Using real-time data obtained from the National Control Centre (NCC) in Osogbo, the network was modeled in two analytical environments to determine the most efficient application for representing real-time operational behavior.

Contingency analysis was conducted by simulating single line outages within the modeled network to assess the system's response to transmission line failures. The modeling and simulation were performed using the Power System Laboratory Environment (PSLE) and the Power System Analysis Toolbox (PSAT), both integrated within MATLAB 2023a. The primary goal was to obtain the Power System Network Contingency Ranking (PSNCR) through Artificial Neural Network (ANN). Two key performance indices—the Voltage Contingency Deviation Index (VCDI) and the Power Contingency Deviation Index (PCDI)—were employed for ranking.

The ANN-based control system effectively reduced voltage deviations, improved real and reactive power flow, and minimized losses under contingency scenarios. The ANN controller was installed at locations with the highest voltage instability,

particularly at the Adiator Transmission Substation (TS).

During testing, the removal of the transmission line between Onitsha TS and New-Heaven TS caused a 12% reduction in overall power availability, demonstrating the sensitivity of the network to line outages. The results demonstrated that the ANN model provided improvements across all parameters. The VDI obtained was 4.87%, indicating better voltage stability performance. Similarly, the PDI was 26% for the ANN, confirming that the ANN achieved great reduction in power deviations after line outages.

In conclusion, the ANN significantly enhanced the reliability and power quality of the Nigerian 330 kV transmission network under contingency conditions. Based on the findings of this study, it is recommended that the Artificial Neural Network (ANN) model be adopted for improving power flow analysis and minimizing the effects of line outages. The ANN model is also recommended for implementation in large-scale power system contingency management to achieve higher operational stability and resilience. Future research should also examine the performance of other intelligent algorithms such as Adaptive Neuro-Fuzzy Inference System (ANFIS), Decision Trees, Random Forests, and Fuzzy Logic, and use optimization tools to determine the most effective placement of these models within the network. In addition, contingency ranking analyses using the Voltage Deviation Index (VDI) and Power Deviation Index (PDI) should be extended to cover the entire Nigerian 330 KV transmission grid to provide a more comprehensive understanding of system vulnerabilities and the performance of intelligent control devices. The integration of Distributed Generation (DG) systems, especially those using renewable energy sources, should also be explored to assess their role in enhancing voltage stability and reliability during contingency conditions. Overall, this study contributes to knowledge by demonstrating that the

application of an Artificial Neural Network (ANN) model can significantly improve the stability and reliability of a power system network under contingency events such as transmission line outages. The ANN achieved performance improvements exceeding 5%, a result not reported in previous literature, thereby setting a new benchmark for intelligent control-based contingency management within the Nigerian 330 kV transmission network.

References

- Anyaka, B. O., & Ozioko, I. O. (2019). *Transmission line short circuit analysis by impedance matrix method*. *International Journal of Power Systems Engineering*, 15(4), 201–209.
- Bhosale, K. V., Dhapatkhar, R. V., Kolpe, S. S., & Malokar, A. S. (2024). *Analysis of fault in transmission line by using MATLAB/Simulink*. *IEEE Access*, 8, 98456–98463.
- Ezeonye, C. S., Atuchukwu, J., & Okonkwo, I. (2024). *Effect of Unified Power Flow Controller (UPFC) integration on the Nigeria 330 KV power network during line contingency*. *IEEE Africon Conference Proceedings*, 245–252.
- Kundur, P. (1994). *Power system stability and control*. McGraw-Hill.
- Mohanty, A., Ramasamy, A., Verayiah, R., Bastia, S., Dash, S. S., Cuce, E., Khan, T. Y., & Soudagar, M. E. M. (2024). *Power system resilience and strategies for a sustainable infrastructure: A review*. *Alexandria Engineering Journal*, 105, 261–279. <https://doi.org/10.1016/j.aej.2024.06.092>
- Obi, O. K., Nwobu, C. C., & Odigbo, A. C. (2025). *Critical contingency analysis: Enhancing stability in Nigeria's 330 KV grid*. *International Journal of Electrical Engineering Research*, 12(2), 67–79.
- Stevenson, W. D. (2014). *Elements of power system analysis* (6th ed.). McGraw-Hill.
- Yaabari, N., Odu, P. O., & Ojobe, O. O. (2021). *Analysis of three-phase transmission line fault using MATLAB/Simulink*. *Nigerian Journal of Technology*, 40(3), 153–161.